

## **Automatic Meter Reading System: A design report**

**"Creating a hybrid network is the key to Automatic Meter Reading System for demand side management."**

**1. Background:** AMR is quite an old concept at its root, but its advantages were not realized till the networking concept started taking big leap to solve the problem that got created due to technological gap in the race of technology itself. Automation in reading meters was given a shape way back in 80s and 90s. Many ways and means of technology was put forward to realize this. But, due to the absence of strong purpose and improper timing, it could not see the growth of technology around it, to make it a viable initiative from the market standpoint. So instead of having a strong technological out come on AMR, automation technology started breeding in process control instrumentations and rose to great heights.

**2. Purpose of Automatic meter reading system:** Way back in 70s to 90s, stress was on generation of more and more power and energy, and distribution network was under evolution with the concern of providing energy to masses. Later in 90s, developed nation soon realized that one may need to incorporate management issues related to energy for managing the growing demand for energy i.e., Demand Side Management has to be in place for proper energy management, conservation, utilization, efficiency and environment. It was soon realized that the true bottleneck in demand side management is in effective Automatic Meter Reading. Thus to carry out demand side management, an effective AMR is required.

### **Demand Side Management:**

As mentioned in background, economical issues, growing market changes, and technological discontinuities drive changes, and subsequently opportunities get created. In context to economics, higher construction cost and investor concerns forces better utilization of generation and distribution system, resulting in real time pricing based on demand, supply and cost. Interestingly, market competition always puts downward pressure on the price and margin, and thereby threatens the market share, customer loyalties and requires consolidation, there by open possibilities high margin, faster growth and unregulated business. Technological innovation patches the discontinuities, there by drive the integration of networks -PSTN, PLC, WL, Internet, control, data, audio, video – internet connectivity etc.

The confluence of these forces puts pressure on all parties, seemingly on conflicting goals.

**Utilities:** need way to reduce cost, charge realistically, to increase customer base, identify new revenue sources, satisfy customer and shareholder and ultimately remain viable entity in the market.

**Generation companies:** need way to have effective utilization of produced power, reduce no load and peak load losses effectively and efficiently match the dynamic demand.

**Consumer:** needs low cost, dependable system, economical, ecological sound energy source.

**Technology companies:** need to bring solution to market in time. Time to market determines leadership, growth and survival.

**Govt. Institutions:** need trust of its constituents, economic climate conducive for growth with Adherence to the myriad laws.

**3. Key challenges:** The key challenges one faces, in this technological domain are

- ✓ Effective Automatic metering system,
- ✓ Building up network for communication appropriate to topological distribution of meter and the hierarchy of operation from the electrical network system.

- ✓ Built up of backend data management, communication and control system.

**Effective Automatic metering system:** Automatic metering can be carried out in many ways. One of the intermediate solutions that customers may have seen is reading meter using palm devices, hand held computer, wireless drive by systems etc. So a meter reader, need not look at the meter to read it. He can pass by the customer's place and have a meter reading on his hand held device. These types of metering system is certainly an Automatic meter reading system but does not constitute an elaborate mechanism for effective automatic meter reading system. The effectiveness in automatic metering system can only be established if the ground for demand side management of energy is laid on the daily basis and is scalable as per the hierarchy of customer and participating business entities. This mean that meter reading activity cannot be treated as an event that takes place once a month or twice a month only for generating bills.

Then, this means that meter has to be read as often as possible and whenever required, the meter data should be made available for analysis and management purpose. The only compelling mechanism that can lead us with metering data on the desktop is by having an active network of meter. Thus one of the prime requisites for carrying out demand side management is to have metering devices on network. Perhaps this agenda of having network is only a broader idea and shall require real engineering to be carried on the product to make it a viable proposition considering other key challenges posed by the meter types and power system hierarchy. Creating a cost effective network itself a big challenge for effective AMR. Architecting the networking and sub-networking sphere of this domain for more challenges like bringing different types of meter on to network and also the topological distribution of meters. Topological distribution of meter poses a big challenge on choosing medium of communication for bringing metering system onto network. Cost effectiveness of bringing meter onto network when meter poses a challenge from topological reason is another issue to be considered. And if this is does not turn out to be an effective proposition, then how data correction is incorporated in the back end software becomes a tactical issue. The other challenge posed is related to the data transmission from the meter. Different types of customer have different type of metering systems. Say for example, a residential customer has a metering system which is 1 phase and 3 phase type and meter reads only KWhr as a parameter for energy consumption and where as an industrial consumer have a metering information consisting of KWhr and maximum demand, and some of them trivectors meters installed for carrying out metering for all the three energy vectors of importance. Apart from this, meter needs a periodic check as well from the remote location and should also have theft prevention mechanism along with the encryption.

If we consolidate the above mentioned challenges, then it broadly means that AMR on the meter side should have :

1. A Choice of communication interface that can latch to network
2. An interface with the meters of different type and is scalable.
3. A standard interface that can cater to vast class of meters in the field.

And should answer these questions:

1. How a meter reading and communication device at meter layer is of low cost?
2. What is strategy of acquiring meter data at the host sub system?
3. What are intermediate sub layers that need to be established for cost effective communication to the data center?
4. How do one make a judicious choice of communication medium?

**Challenges posed at the back end software development:** Considering the issues at the metering layer, communication system layer, intermediate communication devices are

through, then the issue that remains is building up a data acquisition system and data storage system, and then building up service provisioning on the data acquired.

In the subsequent section we propose an outline of our product and product architecture. Interestingly, we are the only company who completely characterizes the key issues and problem associated in implementing AMR and developing its network. Presently most of the companies in the world pursue this issue on any one aspect of AMR and therefore shall not be in a position to reap the benefits of AMR for its client. Our product architecture caters to various problems that arise in the field on implementing AMR like meter type variations, customer level variation, topological distribution of meter related issues, communication related bottlenecks, power system hierarchy, developing and structuring a cost effective network, databases and web related issues etc.

#### **4. Commercial Benefits:**

1. **End customer:** Time of use tariff can be implemented and implies lesser electricity bills. Can help in changing consumption behavior of the customer. Energy saving and as well as usage is rewarding.
2. **Utility Companies:** If consumption pattern is well planned and controlled, then it means increased revenue from the utility standpoint. This is because they can get cheaper power from the generation company.  
Loss due to faulty equipment can be identified easily and removed, thus again results in savings and revenue increase.  
Load balancing can also be taken care of effectively.  
Line losses is greatly reduced because of changed behavior of end Users.  
Help automate the meter reading system and billing systems  
Prime requirement for de-regulation to take off effectively.  
Load curtailment and localized generation can be effectively managed based on the instantaneous demand requirement.
3. **Generation companies:** Can plan generation in advance based on the requirement. Optimal cost of production of power can become a workable model. With the help of localized load flow solutions, optimal generation can be planned. Any generation beyond optimality can have premium for it. Centralized load dispatch center activity can be decentralized to a larger extent. A load dispatch center can work more like a regulator for implementing energy trading systems, a power flow controllers instead of becoming an authority for governing the power flow and load shedding companies. The role of load dispatch center can be streamline between utilities and generation companies.
4. Open area for new business lines based on the built up of network. Audio video stream, security services, Video on demand, Vehicle tracking system, smart home and appliance control, etc. are just few of them. It opens a new revenue stream.

**How AMR business is classified:** In the above section we have stated the bottleneck that may arise in developing technology of AMR. To carry out an effective AMR and implement demand side management, we have seriously taken into consideration the bottleneck that may arise. Usually such problem can only be looked upon, when companies go for deployment of their solutions. One of the reasons why AMR has not taken off in full-fledged way is because of this. The common practice of technology companies on this line is that they consider one of the technology line and start developing solutions and when they go for field deployment and see lot of unknowns (which has no place in their design considerations), lands up in problem with too much of restriction in their solution. And soon

another half bake solution gets prepared. Simple example could be, company finds wireless as a technology suitable for AMR. They design solution which goes in the meter, now fitted in the meter, say of consumer whose electricity bill is not even Rs 200 a month. The wireless AMR solution becomes an overhead there. Second is, a solution goes in the meter which is at remote location, well not in reach again, solution is half backed. Another case is, a customer is highly theft oriented, wireless solution is deployed in his meter, then he plays a trick on it and corrupts the channel. Interestingly, all the case can be handled by technology but not by same solution. To tackle some of these situations in the field, we need

1. A product line (instead of product only) to address the variations in the field. This issue can be addressed by the technology having a broader understanding of this field and power system distribution network. **(Technology)**
2. Energy Consultant on the job to carry out analysis on the field for finding right product combination to be deployed from the product line effectively. **(System Analyst and System Engineer)**
3. And a deployment team, who need to know communication system and power systems. **(Strong implementing group)**

Interestingly, we are the only company in the world, who has taken up problem of AMR in this broader perspective and prescribing solutions and solving it with help of our technology- product line, consultant and deploy simultaneously. In the subsequent section we are presenting our product line that will spawn entire range of metering network in its sphere.

In general, any distribution network from power plant to the end consumer, is as shown in the figure below:

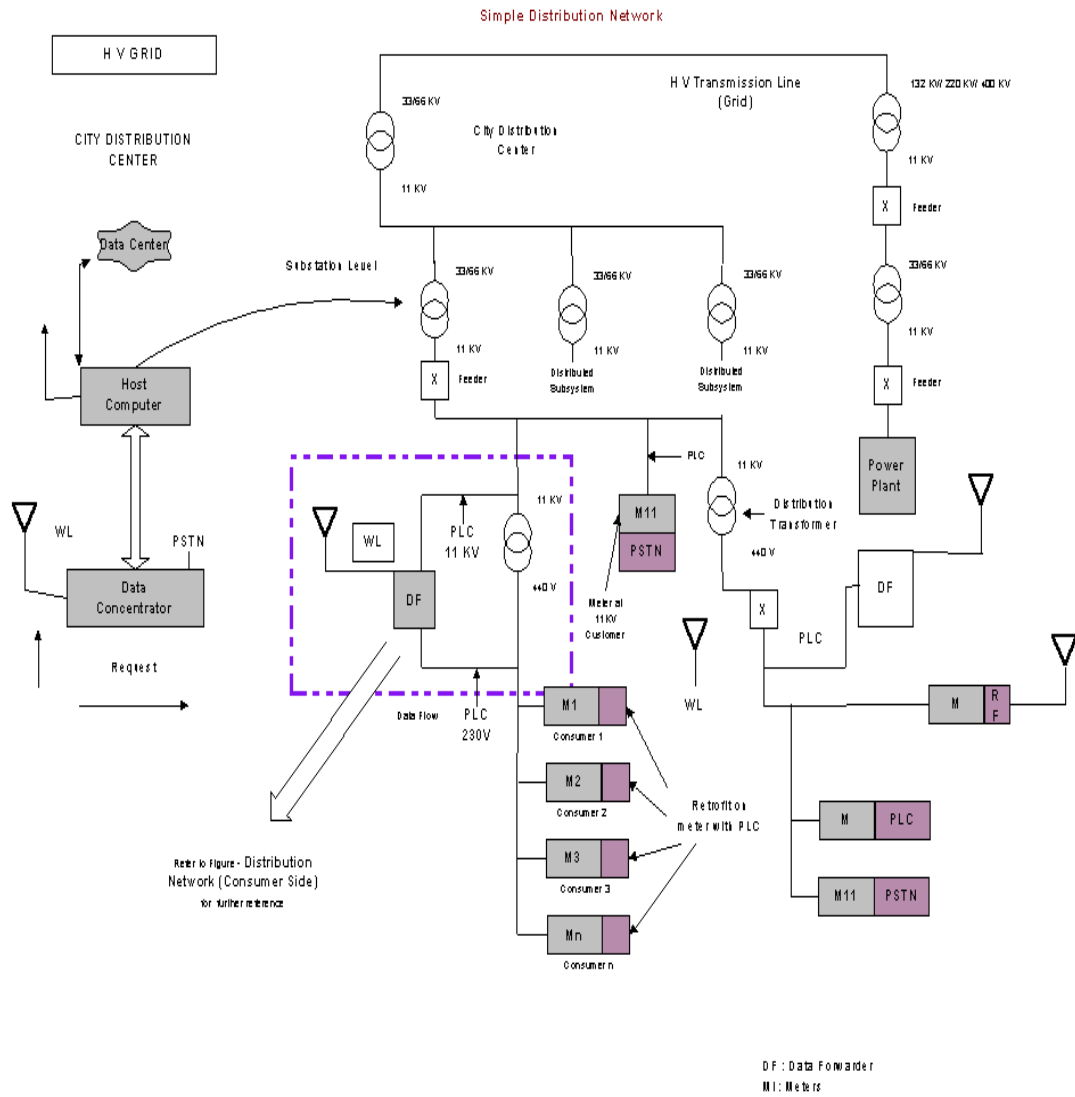

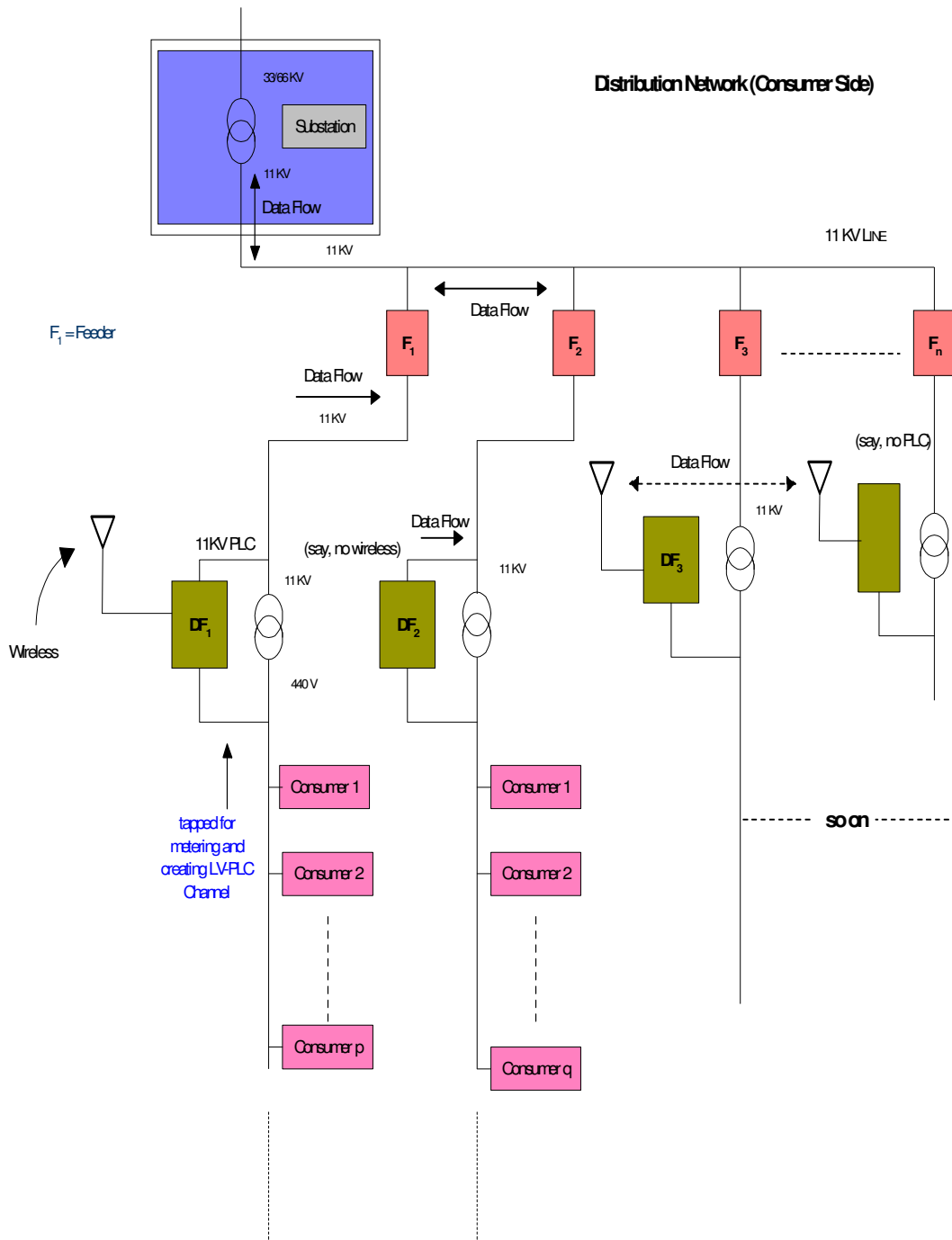

### PID POWER MANAGER

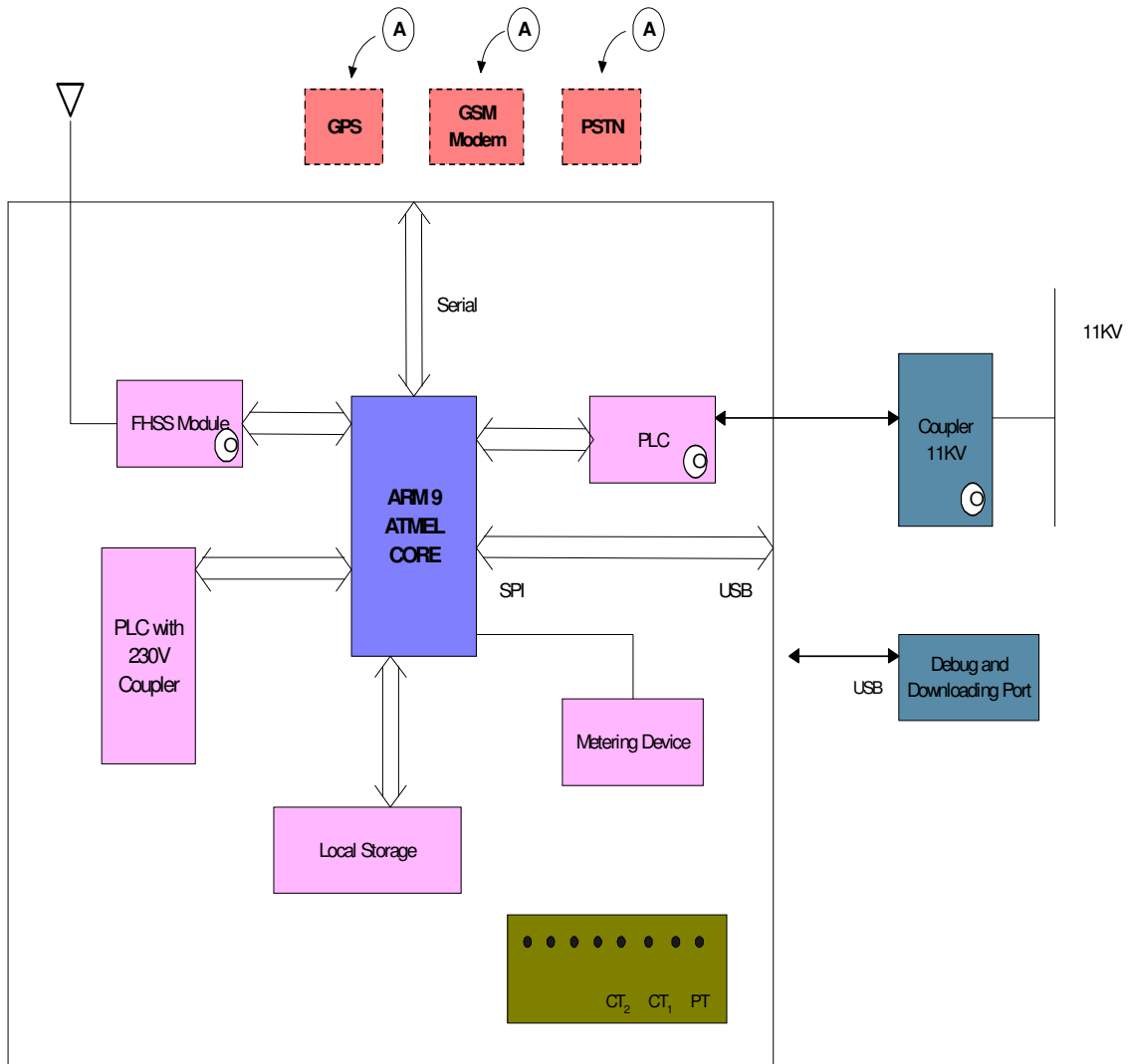

### DATA FORWARDER

Present Usage of mip: 20 mips  
 For future use: 100 mips  
 -----  
 120 mips

Data Forwarding Device

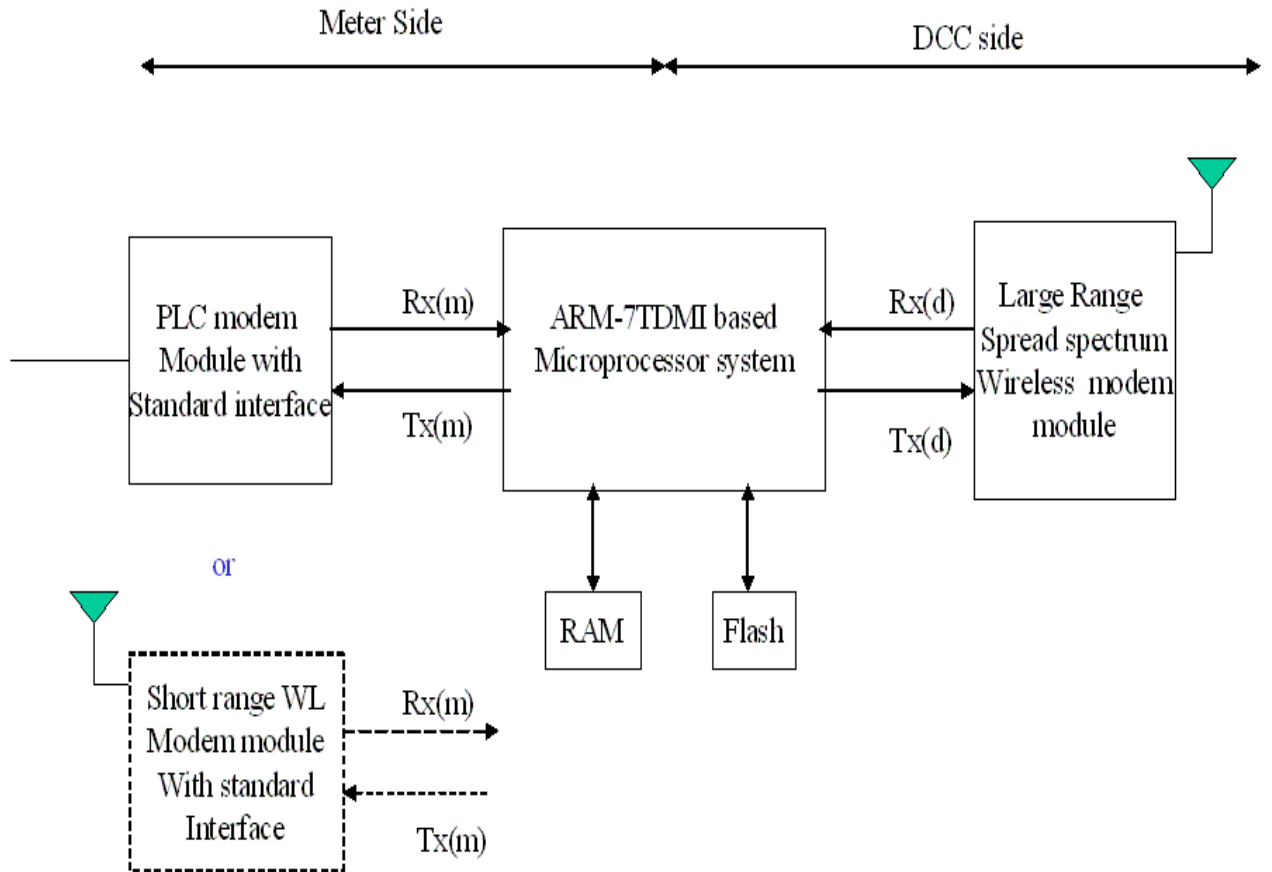

Data Concentrator Computer

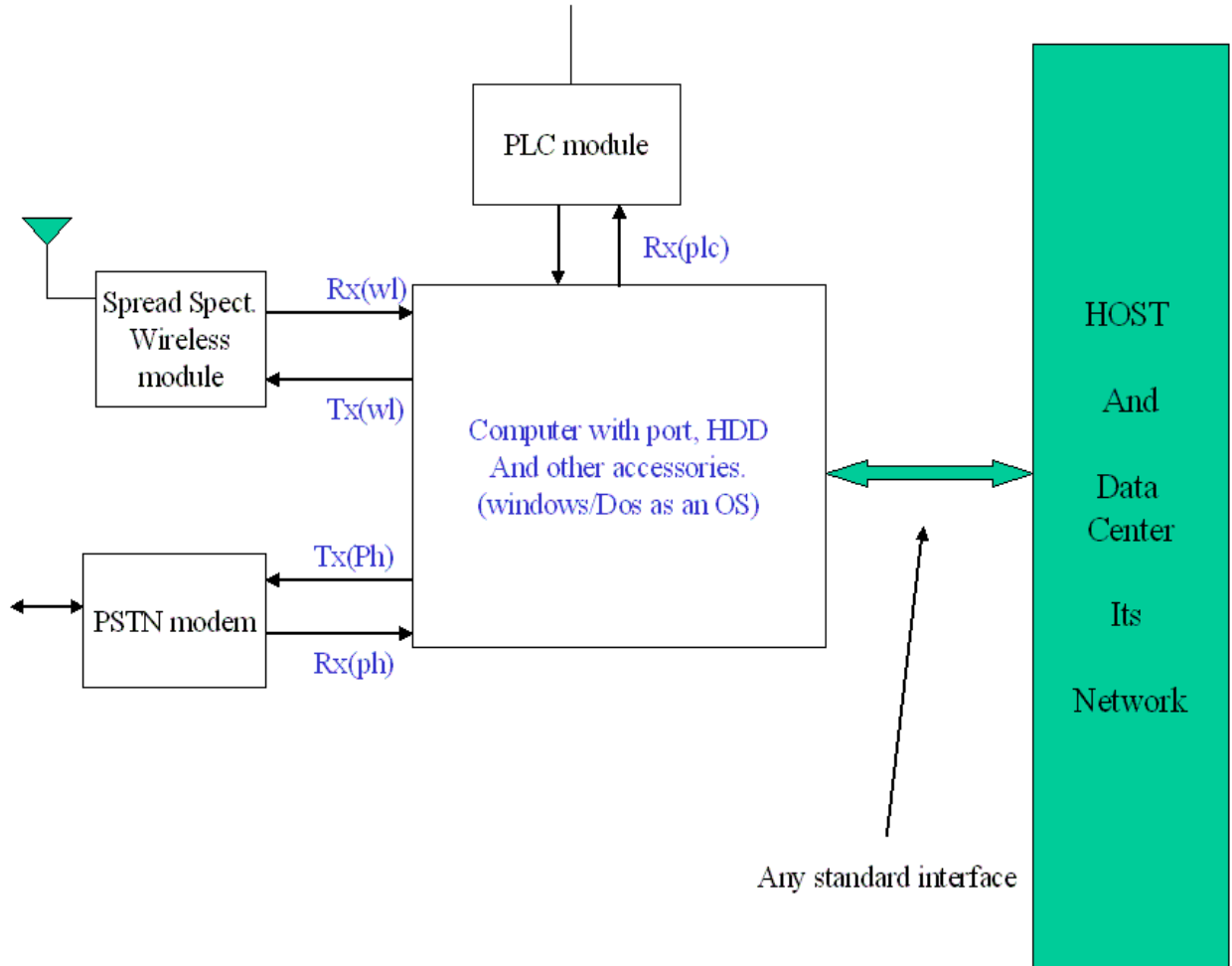

### Product Architecture

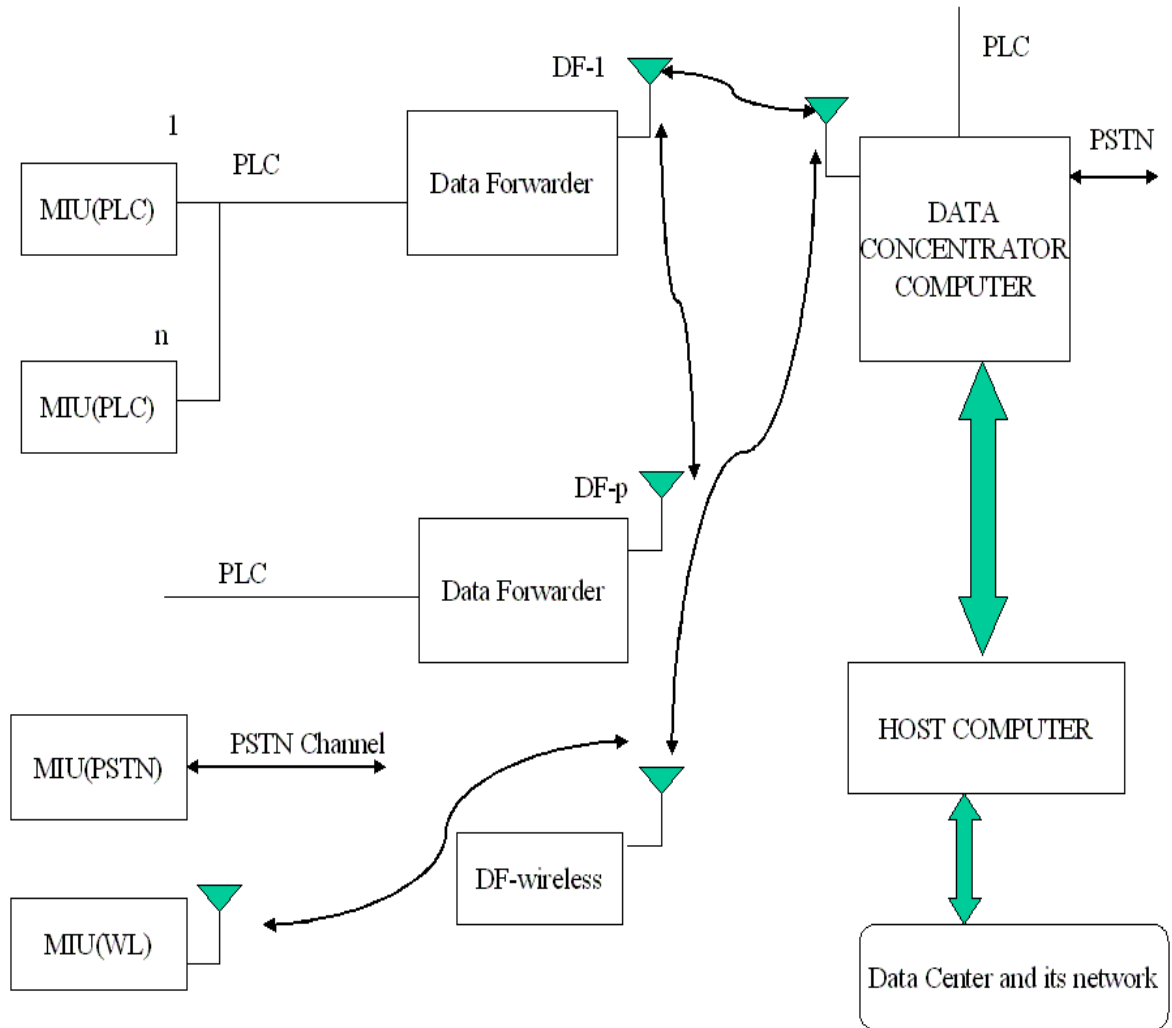

## **Product Architecture and its components:**

The salient feature of product is that it provides solution for

1. Automatic meter reading,
2. Outage detection,
3. Energy auditing at various Hierarchy in electrical network,
4. Automated billing,
5. Energy information system,
6. Load management system,
7. Load curtailment etc.

## **5. How to build up an AMR network:**

### **Automatic Meter Reading System: Data Pooling Approach:**

**5.1 General Description:** The system comprises of a Meter Interface Device, Data Forwarder (DF), and Data Concentrator computer (DCC) and Host system. Meter interface unit just keeps track of meter reading to which it is fitted into. Meter interface has a modem of the type PLC, wireless-fsk, PSTN type for providing the connectivity to Power line or wireless or Phone line. Each MIU is connected to a forwarder that connects meter interface unit to Data concentrator computer. Each data concentrator is connected to Host computer of Data center (HCDC).

**5.2 Meter Interface unit:** MIU comprises of PCB retrofitted in pulse energy meter. The circuit board comprises of the following major components:

1. A modem module (any one of PLC or PSTN or FSK/SS wireless). For this design, we prefer PLC. PLC modem module has a bit rate of 2400bps. We can also use 19.2Kbps or 100Kbps based on the need. Modem module uses propriety power line transceiver chip set.
2. A power line coupler for 230 V.
3. Micro controller with external EEPROM, which has a spi port. A unique silicon ID is fused in this EEPROM. Through hand held device meter number, initial meter reading and meter constants are programmed.
4. A power supplies converting AC to DC and is used for feeding each sub modules.

**5.3 Data Forwarder:** DF comprises of stand alone PCB. The circuit board comprises of the following major components:

1. A PLC modem module.
2. A low-end microprocessor system like ARM7TDMI with 1 MB of RAM, 24K of EEPROM with two serial ports. Silicon ID for this device is fused in EEPROM.
3. A wireless spread spectrum modem module with serial interface is integrated along with microprocessor-based system.
4. A power supply to feed all these three major units.
5. A weather proof encasing for all these.

**5.4 Data Concentrator Computer:** DCC comprise of stand-alone computer. It has following major components:

1. A stand-alone computer may be with low-end configuration, networking ports and storing capacity on hard disk drive etc.
2. A spread spectrum modem module with interface to computer through port.
3. A PLC modem module with connectivity on port of the computer.
4. A real time clock on the motherboard of computer.
5. PSTN modem connectivity with computer.

**5.5 Host computer of Data center:** HCDC comprises of host computer along with network of computers. It has following major components:

1. A high-end computer, which is connected to DCC on one side and is on network of computers for managing data center.
2. Host system is a high-end system consisting of Pentium-4 computer system with large RAM (64 MB) and HDD capacity of 30GB.
3. Host is connected to the network of computers through Ethernet or wireless LAN network.

**5.6 Purpose of the System:** The purpose of this Automatic meter reading system is to provide low cost AMR facilities in the system. It has all the features of Automatic meter reading system with the innovative data pooling strategy to bring cost down for the end customer. In this strategy the complexities are kept away from the end customer and is sequentially brought up into different layer of the product architecture like forwarder and data concentrator computer and Data center, whose cost gets distributed.

### Detailed Operational Description:

The following abbreviations are used in the detailed description:

MR	Meter reading
CM	Check meter
TOD	Time of day at which meter has to be read.
MD	Maximum demand
S&S	Store reading for whole day and then send on request.
PLC - HS	PLC high speed
PLC-LS	PLC low speed
WL-SS	Wireless spread spectrum
PSTN-IB	PSTN in bound (sharing line with different number)
PSTN-OB	PSTN out bound
RT	Router.
LV, MV	Low voltage (230V) Medium Voltage (11kv)
PLC /WL	Power line carrier/Wireless

### Meter Interface Unit:

Meter interface unit has two major component blocks. One is meter interface side and other is modem. Meter interface side consists of a micro controller and EEPROM. Meter interface side counts the pulse coming from the meter, converts it into meter reading and stores it in memory. It also implements a protocol for two-way communication to report the meter reading and meter activity to the DCC through modem. So meter side interface implements protocol for two-way communication to modem and to data concentrator computer. The call to MIU is always initiated by DCC through forwarder. There are four possible types of MIU. The classification is based on the operations that are handled. The type specification is provided in the protocol, and only occupies two bits in communication.

Sino	MIU - type	Operation	Connectivity
1	Type-1	MR/CM/TOD/RT	PLC-LS/PLC-HS/WL-SS/PSTN-IB
2	Type-2	MR/CM/MD/TOD/ S&S	PLC-HS/ WL-SS/PSTN-IB/PSTN-OB.
3	Type-3	MR/CM/TOD/Mach-M with S&S	PLC-HS, WL-SS, PSTN-IB
4	Type-4	Trivector meter	PSTN-IB, PSTN-OB

To meet the varying requirement of topological distribution of meters, broader consumption level, we have categorized the meter interface component. Based on the broader consumption level, one can decide which type of meter interface unit or its sub component should be integrated with meter. This provides a great deal of flexibility and justification of doing AMR for large utilities.

The components that are required to interface meter and provides the physical layer communication to AMR systems can be categorized as follows:

S.No	Component	Connectivity	Purpose
1	MIU	PSTN	For high-end customers like C&I type.
2	MIU	PLC	Suitable for both medium and high end customer. Deployment should

			also consider topological issues.
3	MIU	WL(network based)	Suitable for very high end customer
4.	MIU	WL (very short range)	Medium level customer where in sub grouping of MIU is possible.
5.	MI	Grouped in PLC	Very low end customer and where meters are near by in high density
6.	MI	Grouped in short range WL	Lower medium and very low end customers

**Data Forwarder Unit:**

DF is device that forwards the data coming from DCC to the MIU or data coming from MIU to DCC. It also acts like a router for other DF units connected to different set of MIUs which may not be accessible to DCC directly. DCC makes request to DF first, then receives meter data through Wireless Spread Spectrum module. The data received by DF from DCC is analyzed either for routing to other DF or send on to PLC modem to obtain meter related information. The response of the meter is also reported back to DCC through DF. So, a DF is a device consisting of PLC-LV modem on one side ( on the meter side and PLC-MV) and WL-SS modem on other side. DF is a router at DF layer as well. Thus DCC can approach remote DF through intermediate DF within reach of DCC. There are three types of DF and is listed below along with specific purpose.

S.No	Components	Connectivity (I/O)	Purpose
1	DF	PLC(LV)-PLC(MV)	Creating PLC network and bypassing transformer.
2	DF	PLC(LV)-WL-SS	Creating a hybrid network with connectivity wireless and PLC
3	DF	WL-SR-WL-SS	To supplement lower medium and very low level consumer. Making it cost effective.

DF cost is a distributed cost. So key of our Architecture is to provide cost effectiveness where ever higher cost components are involved, by which the cost gets distributed and also, if it is a low power consumer then this cost is further reduced. Thus scalability is at every layer of this network formation.

**Data Concentrator Computer:** The main function of this unit is to accumulate the data from the various based meters and push the accumulated information on the Data center network through host computer. Various scheme of meter is implemented in DCC and is governed from DCC. It temporarily stores the information based on the metering condition and forwards it Host unit. DCC has a connectivity with PLC-MV, PLC-LV, WL-SS, GSM, PSTN-IB, OB modems thus acting as device which is collecting data from all possible connectivity on which instrument is hooked up. Along with HOST functionality, it also implements standard protocol at higher layer and integrate with DC.

**Host Computer of Data Center:** HC's main function is to set up DCC parameter related to metering process, managing connectivity related to meters and DF. All the new accounts setup related to meters, DF and network is carried out from this unit. Then acquired data from DCU is pushed on the data center network. Host is an active part of data center but does a dedicated job of setting and managing data concentrator computer. One end of HC is connected through DNP protocol which integrates this with different type of information sub systems of Utilities and Generating subsystems.

**Data Center:** DC is a unit, which manages database of metered data and also provides various services based on the data to utilities, end customer, power companies, and maintenance companies etc.

We are highlighting some of the frequently asked question (**Faq's**) so as to have clarity of what solution we are offering.

**FAQ1: What is the role of DF(P1D power manager) when one can have direct access between DCC to MIU?**

**ANS:** The tactical reason for having intermediate device like DF is to bring an extra degree of freedom positioning the device so that topological distribution related issues could be tackled. It is interesting to see this issue in the light of MIU, DCC and Host combination. Here in this architecture, MIU locations are fixed, then DCC location will also be fixed. So the grouping of MIU is totally dependent on the location of DCC and is fixed. So this does not allow MIUs to have subgroup and groups, which is a requirement that is forced due to topological distribution of meters. And suppose this grouping is done using DCC then each DCC is under-utilized, and proposition would not be even cost effective. Just by adding a device DF and extra degree of freedom is attached to reach meter in group and subgroup level, which is not present in other architecture. So just by adding two bytes in protocol, one is able to reduce the cost of entire system, and get the flexibility in tackling the problem of distribution of large number of meter scattered over large geographical locations.

**FAQ2: How DF can be used for distribution transformer metering. Do we need to have separate metering and communication system at Distribution Transformer?**

**FAQ3: Why we need to have network of Data forwarder at Distribution transformers.**

**FAQ3: How data forwarder can be used for wide area measurements.**

**FAQ4: Do we need to do AMR at every meter?**

**FAQ4: Can we have a mathematical representation all the components involved in AMR?**

**ANS:** Each AMR subsystem  $\cong$  HC  $\cup$  DCC  
 Each DCC = {DF<sub>1</sub>, DF<sub>2</sub> - - - DF<sub>n</sub>}  
 Each DF<sub>p</sub> = {MIU<sup>p</sup><sub>1</sub>, MIU<sup>p</sup><sub>2</sub> - - - MIU<sup>p</sup><sub>k</sub>}

**Add on benefits and Future of AMR efforts:**

Consider that a framework of hybrid network is established and the bottleneck of effective AMR is resolved, then this entire effort opens the opportunity to new business streams, some of them in line with utility energy management and some of them as an additional communication services. Some of the additional revenue streams for the utility are:

**Energy Trading:** Once the proper network is established then, other than demand side management, it opens the opportunity for utilities and Generation Companies to take part in energy trading, effective management of generating sub systems even at the customer location.

**Generation planning and management:** AMR concepts outcome can be used even for generation planning and management.

**Home Automation:** Intelligent home Appliance control systems and development of home security network, Tracking systems, Audio and video streaming solution for last mile and developing hybrid telephone system - Interestingly all these will also lead to extended service and revenue model.

**Standardization of Automatic metering system:** Presently AMR does not resort to standardization. Sooner some broader standards shall be freezing. To some extent ANSI has come up with standardization scheme for communication using PSTN for C&I customer. One of the reasons why standardization is not progressing is because of absence of network framework. The instance network framework is freezing and soon standardization will take place. Interesting we are the only company which lays foundation for hybrid network and try systems and devices to get developed. Hence it is quite possible that our standard on the product side will get due consideration even in standardization process.

**Wide Area Measurement:** Power system stability is of great consequence for the effective working of power distribution network. Interestingly DT metering network can play an important role in setting the framework for wide area measurements.

**Product Specification and costing techniques:** We outline the product in form of diagram and then we provide specification for the entire product line that may be required for actual implementation of AMR.

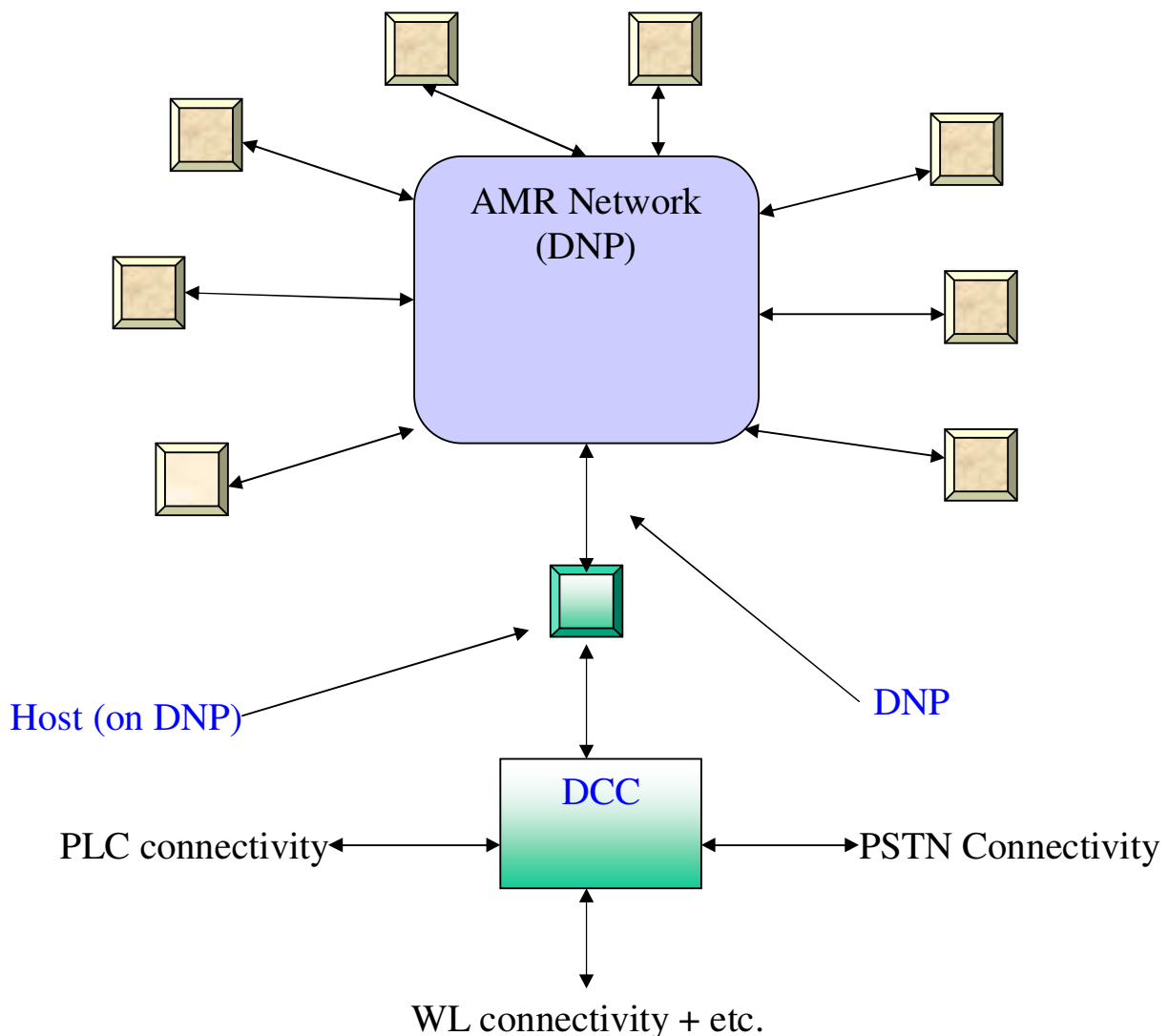

### AMR network at Data center

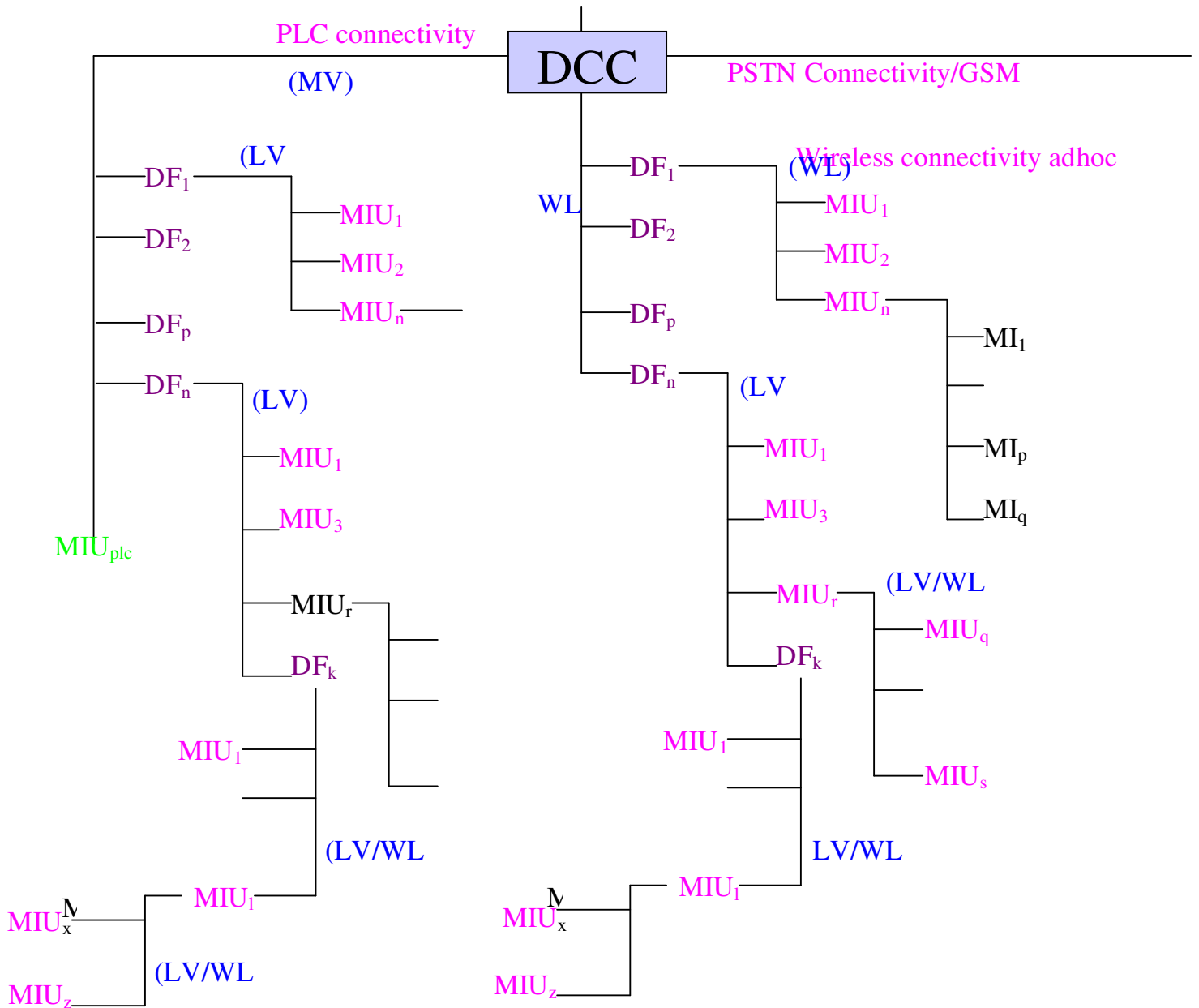

---

*The above figure shows how connectivity meters are achieved. Different types of MIUs and Data Forwarders handle the variations arising in the field. We also have classified consumers and handle the topological variations.*

IMPLEMENTATION STRATEGY FOR DT METERING & COMMUNICATION: AMR

We, **P1D** have a different and a scalable approach towards implementing AMR solution. Our solution systematically incorporates the concept of intelligence on customer-to-customer basis, creates a framework integrating accountability about the individual customer, on the basis of intelligence accumulated in him through experience. This becomes a cost effective way of implementing AMR to remote customer with proper justification of achieving Demand Side Management and supervising and controlling the consumer behavior for the good.

### Simple Distribution Network

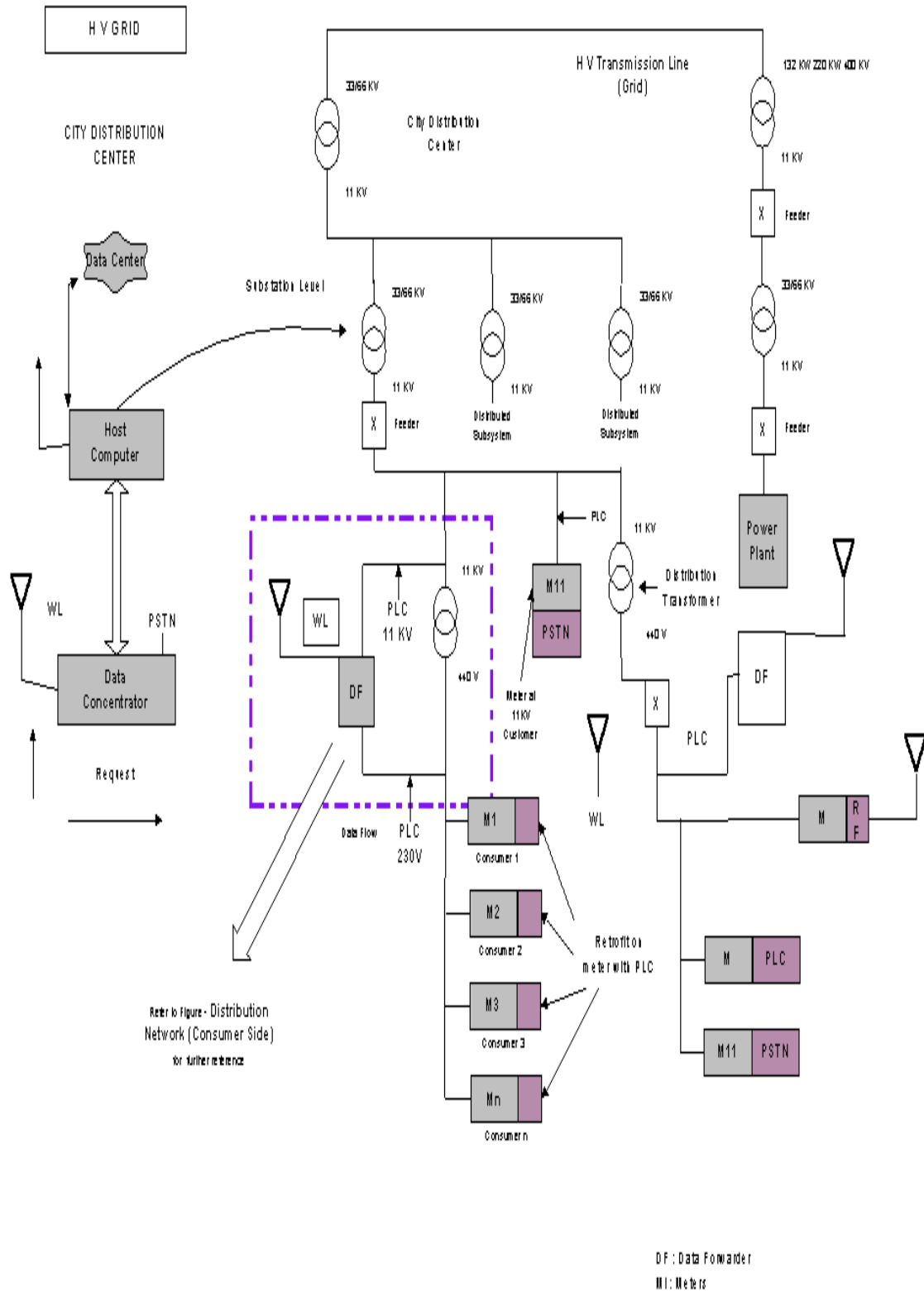

### **P1D's approach towards implementing AMR:**

Consider a simple distribution network as shown in the figure. In the hierarchy of distribution, one will have the following components:

Power plant

- Ultra High Voltage Transmission UHV Grid (110KV, 132KV, 220KV, 440KV) attach to many such power plants.
- From the grid, power arrives at city utility and power voltage level is brought down to 33KV/66KV for local distribution
- From the City Substation, power is brought to Substation for distribution to Distribution Transformer, and voltage is brought down from 33KV/66KV to 11KV.
- From 11KV, power is brought to 440V 3 $\phi$  or 230V 1 $\phi$
- Consumer by enlarge, where one loops for AMR at 230V, 440V3 $\phi$  or 11KV

Now, to implement AMR, we need to have a mechanism, which ideally communicates the reading of consumption to storage/computational device located at substation. This is because, the meter/consumer comes under the jurisdiction of substation. Hence meter read should be made to reach substation. Now the question is, do we need to put AMR device at every place, even where the consumption of power requirement does not have cost justification and have very extremely unfeasible return on investment? If AMR implementation is not planned properly, then return on huge investment will be distant dream as well.

**P1D** implementation guidelines to have a well realizable return on investment for AMR proposes layer approach.

### **Our approach in its layer is as follows:**

- Set up a network between Substation to Data Center (This may already exist, but may not be in the application form for AMR and Demand Response Server Side.)
- Create a Network and Metering System at the Distribution Transformer Side. So, create a channel of communication between 11KV Distribution Transformer to the Substation and implement AMR at the transformer end. This creation of channel communication will open the gates for having communication to remote meter reading.

Based on the history and results matched at the transformer end, implement AMR selectively and intelligently so that two-way communication based on the economy of usage can be established between the consumers to substation through transformer.

### **The factors that governs the implementation of AMR selectively are:**

- Maximum demand of the consumer
- Consumer past record or intelligence accumulated for his power consumption and payments
- Grouping and sub grouping of the consumers with common metering and low consumption sub metering
- Services, end consumer wants to subscribe
- Willingness for multiple tariff system for the consumer, etc.

**Brief description about the product at transformer:**

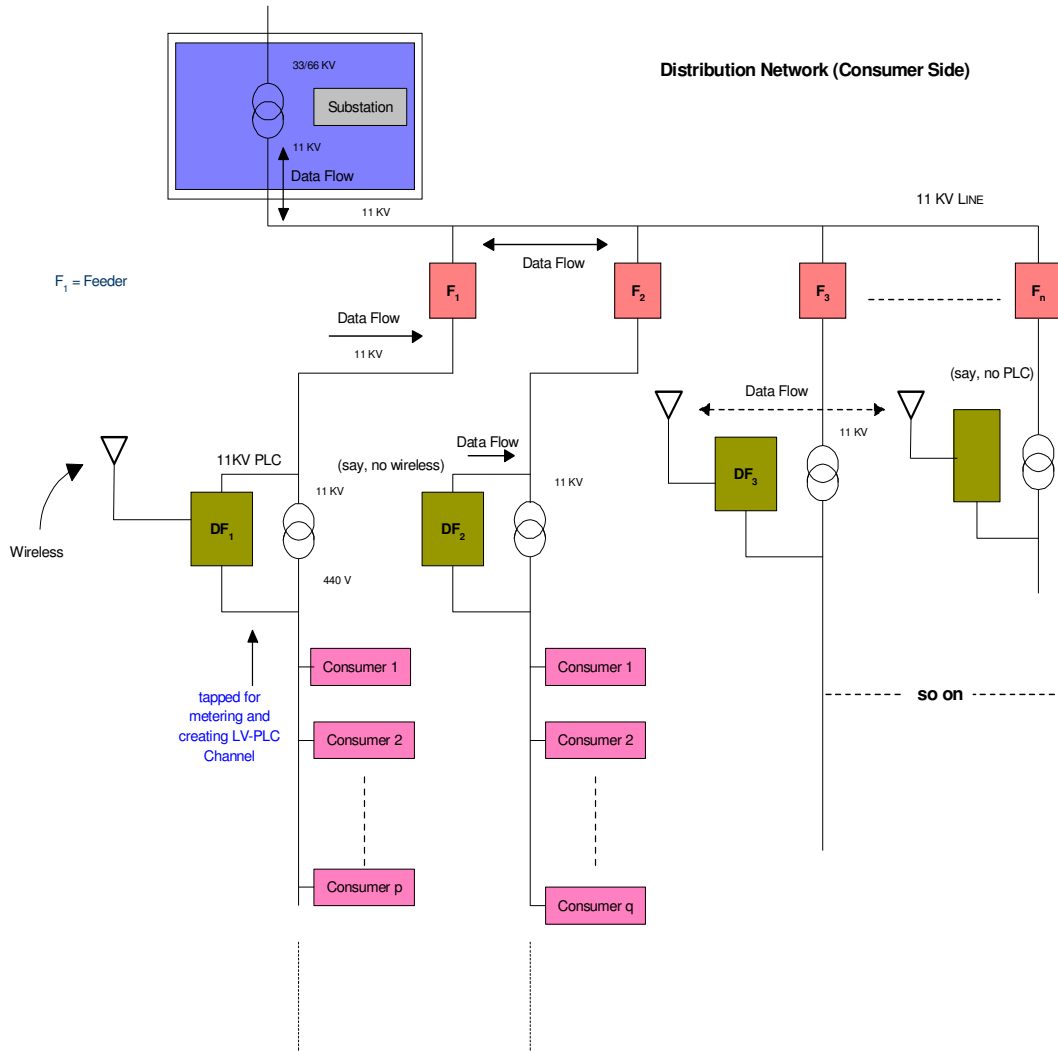

A highly versatile communication system with redundancy and instrumentation deployed at 11KV transformers

### PIDPOWERMANAGER

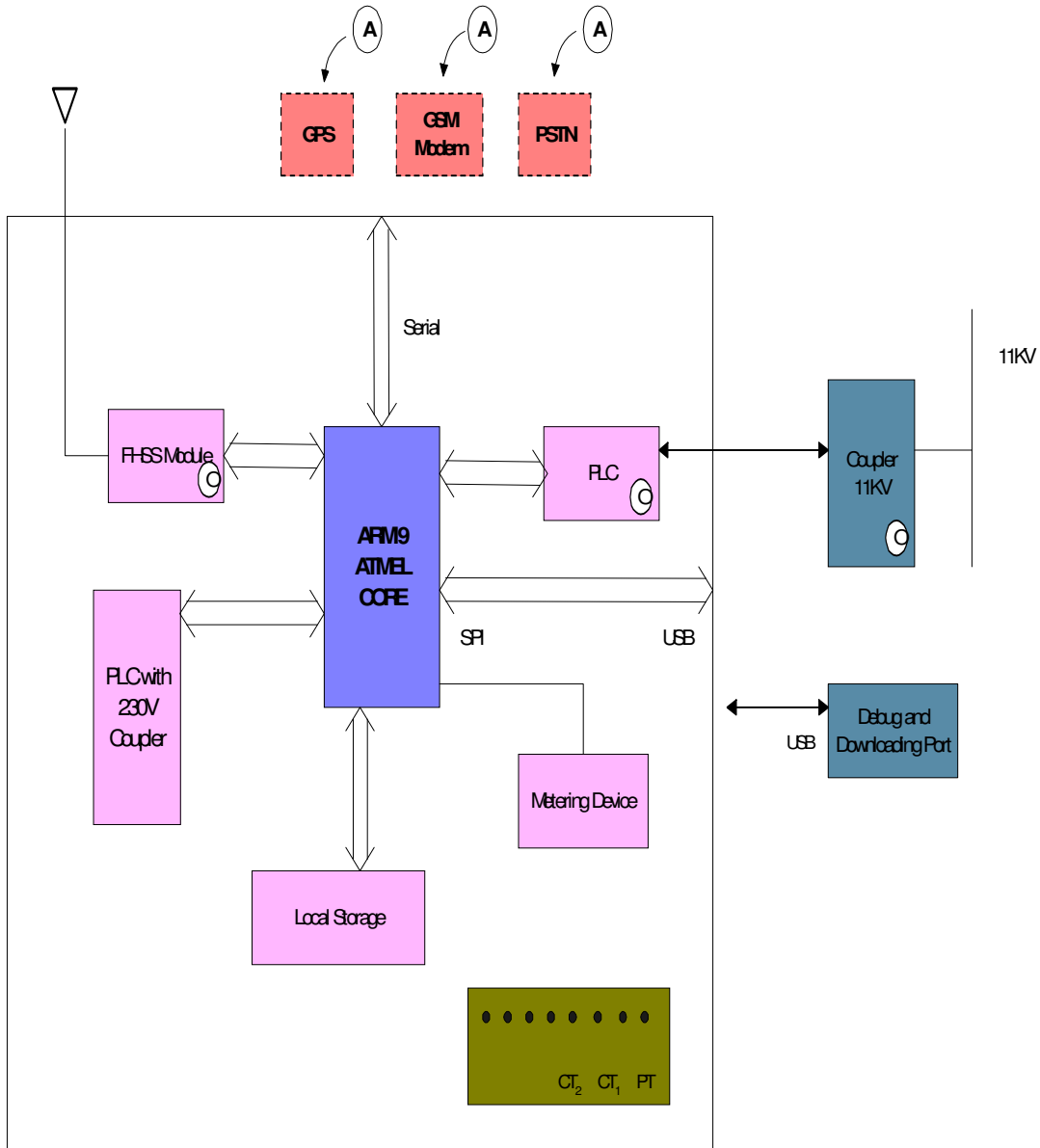

### DATAFORWARDER

Present Usage of mips: 20 mips  
 For future use: 100 mips  
 \_\_\_\_\_  
 120 mips